

**DOCUMENT FEEDER**  
**(Machine Code: C600)**

---

# 1. OVERALL INFORMATION

## 1.1 SPECIFICATIONS

Original Size:	Standard Size (Single-sided Mode only): A3 to A5, DLT to HLT Non-standard Size (Single-sided Mode only): Max. width 297 mm Min. width 105 mm Max. length 1,260 mm Min. length 128 mm
Original Weight:	40 ~ 128 g/m <sup>2</sup> (10 ~ 34 lbs.)
Table Capacity:	50 sheets (80 g/m <sup>2</sup> , 22 lbs.)
Original Standard Position:	Center
Separation:	FRR
Original Transport:	Roller transport
Original Feed Order:	From the top original
Reproduction Range:	50 ~ 200%
Power Source:	24 & 5 VDC from the copier
Power Consumption:	25 W
Dimensions (W x D x H):	550 mm x 470 mm x 130 mm
Weight:	9 kg or less

## 1.2 MECHANICAL COMPONENT LAYOUT

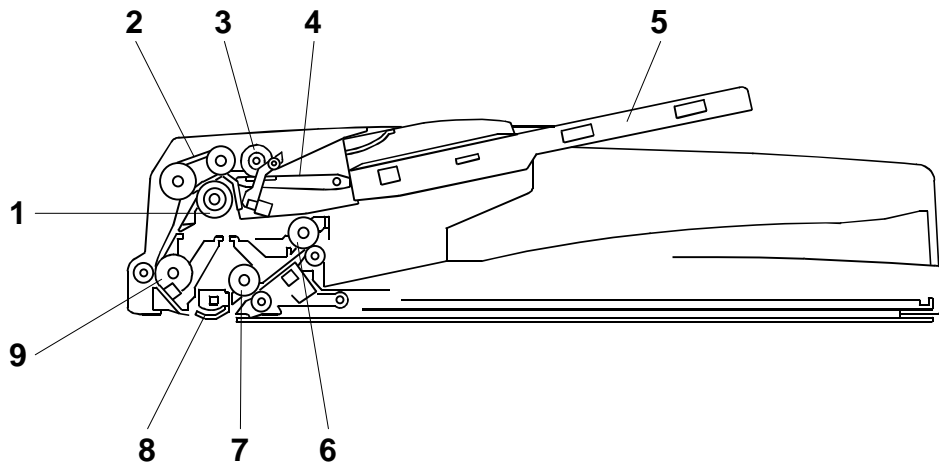

C600V101.WMF

- |                            |                            |
|----------------------------|----------------------------|
| 1. Separation roller       | 6. Original exit roller    |
| 2. Original feed belt      | 7. 2nd transport roller    |
| 3. Pick-up roller          | 8. Original exposure guide |
| 4. Original entrance guide | 9. 1st transport roller    |
| 5. Original table          |                            |

### 1.3 ELECTRICAL COMPONENT LAYOUT

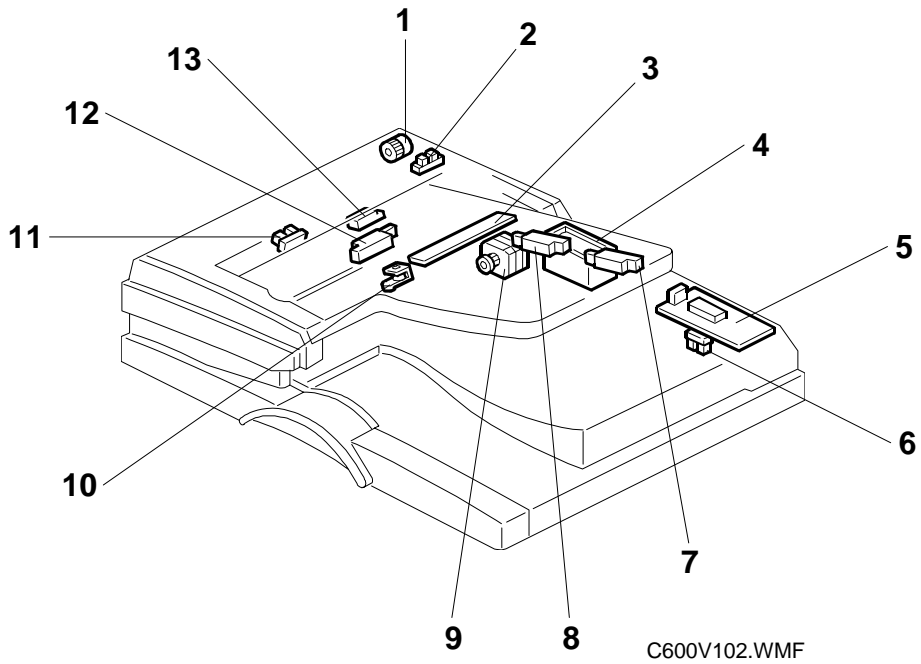

- |                             |                                   |
|-----------------------------|-----------------------------------|
| 1. DF feed clutch           | 8. Original length sensor 1       |
| 2. Feed cover open sensor   | 9. DF transport motor             |
| 3. Original width sensor    | 10. Stamp solenoid                |
| 4. DF pick-up solenoid      | 11. Original set sensor           |
| 5. DF drive board           | 12. Original trailing edge sensor |
| 6. DF open sensor           | 13. Registration sensor           |
| 7. Original length sensor 2 |                                   |

## 1.4 ELECTRICAL COMPONENT DESCRIPTION

Symbol	Name	Function	Index No.
<b>Motors</b>			
M1	DF Transport	Drives the transport and exit rollers	9
<b>Sensors</b>			
S1	DF Open	Informs the CPU of the DF when the DF is opened and closed (for platen mode).	6
S2	Registration	Detects the leading edge of the original to determine when to turn off the DF transport motor and expose the original, and checks for original misfeeds.	13
S3	Feed Cover Open Sensor	Detects whether the feed-in cover is open or not.	2
S4	Original Width	Detects the original width.	3
S5	Original Length 1	Detects the original length.	8
S6	Original Length 2	Detects the original length.	7
S7	Original Set	Detects the original is on the feed table.	11
S8	Original Trailing Edge	Detects the trailing edge of the last original to stop copy paper feed and to turn off the transport motor, and checks for original misfeeds.	12
<b>Solenoids</b>			
SOL1	DF Pick-up	Controls the up-down movement of the original table.	4
SOL2	Stamp	Energizes the stamp to mark the original.	10
<b>Clutches</b>			
MC1	DF Feed	Transfers transport motor drive to the pick-up roller and feed belt.	1
<b>PCBs</b>			
PCB1	DF Drive	Interfaces the sensor signals with the copier, and transfers the magnetic clutch, solenoid, and motor drive signals from the copier.	5

## 1.5 DRIVE LAYOUT

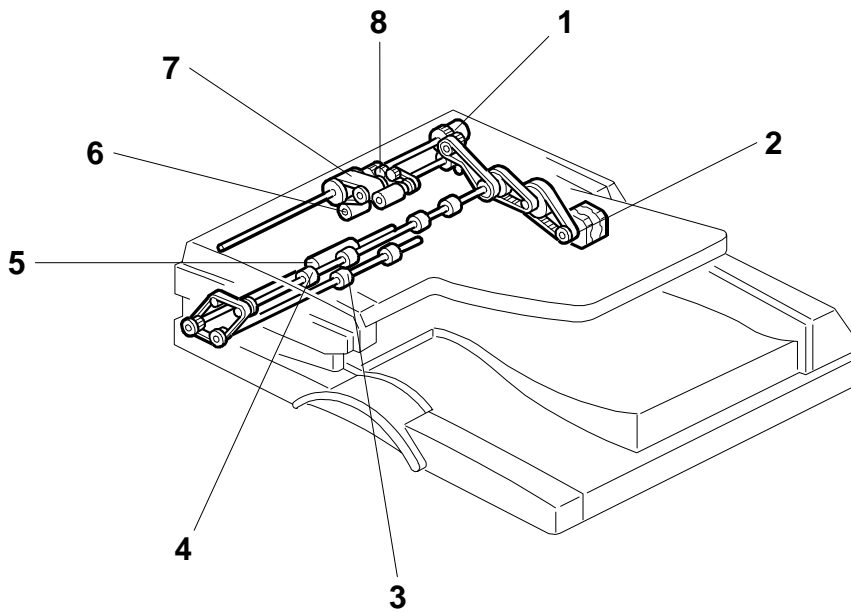

C600V103.WMF

- |                         |                         |
|-------------------------|-------------------------|
| 1. DF feed clutch       | 5. 1st transport roller |
| 2. DF transport motor   | 6. Separation roller    |
| 3. 2nd transport roller | 7. Original feed belt   |
| 4. Exit roller          | 8. Pick-up roller       |

---

## 2. DETAILED SECTION DESCRIPTIONS

### 2.1 ORIGINAL SIZE DETECTION

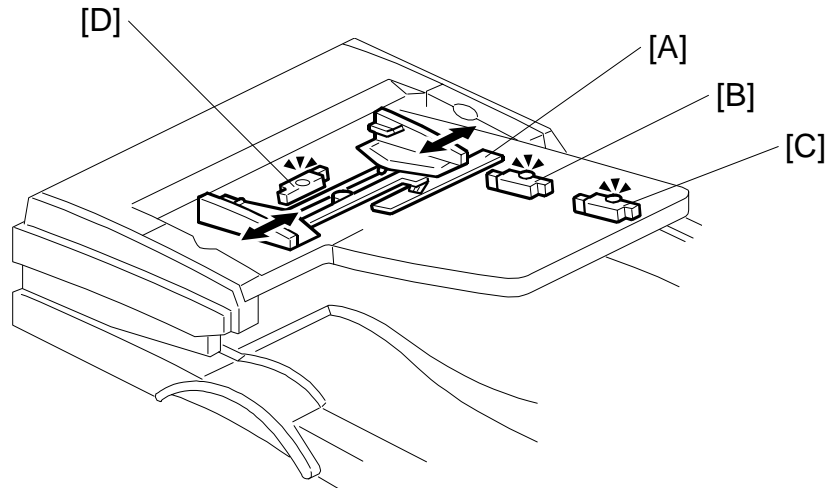

C600D104.WMF

The DF has one width sensor [A] to detect the original width and two original length sensors (-1 [B] and -2 [C]) to detect the original length. The DF detects the original size through the combination of inputs from those sensors as shown in the table on the next page.

When using an original of a non-standard size, the user needs to input the original length at the operation panel.

The original width sensor [A] has four possible outputs (P1 to P4). The output depends on the position of the sliding electrode on the original rear fence.

During one-to-one copying, copy paper is fed to the registration roller in advance, to increase the copy speed. The original exit trailing edge sensor monitors the stack of originals in the feeder, and detects when the trailing edge of the last page has been fed in. This stops the ADF from feeding an unwanted extra sheet of copy paper.

		NA	EU	Original Length 1	Original Length 2	P1	P2	P3	P4
1	A3 L (297 x 420)	X	○	ON	ON	—	—	—	ON
2	B4 L (257 x 364)	X	○	ON	ON	—	—	ON	—
3	A4 L (210 x 297)	X	○	ON	—	—	ON	—	—
4	A4 S (297 x 210)	X	○	—	—	—	—	—	ON
5	B5 L (182 x 257)	X	○	ON	—	ON	—	—	—
6	B5 S (257 x 182)	X	○	—	—	—	—	ON	—
7	A5 L (148 x 210)	X	○	—	—	ON	—	—	—
8	A5 S (210 x 148)	X	○	—	—	—	ON	—	—
11	11" x 17" L (DLT)	● <sub>1</sub>	X	ON	ON	—	—	—	ON
12	11" x 15" L	○ <sub>1</sub>	X	ON	ON	—	—	—	ON
13	10" x 14" L	○	X	ON	ON	—	—	ON	—
14	8 1/2" x 14" L (LG)	● <sub>2</sub>	X	ON	ON	—	ON	—	—
15	8 1/2" x 13" L (F4)	X	● <sub>4</sub>	ON	ON	—	ON	—	—
16	8" x 13" L (F)	○ <sub>2</sub>	○ <sub>4</sub>	ON	ON	—	ON	—	—
17	8 1/2" x 11" L (LT)	● <sub>3</sub>	X	ON	—	—	ON	—	—
18	8 1/2" x 11" S (LT)	○	X	—	—	—	—	—	ON
19	10" x 8" L	○ <sub>3</sub>	X	ON	—	—	ON	—	—
20	5 1/2" x 8 1/2" L (HLT)	○	X	—	—	ON	—	—	—
21	5 1/2" x 8 1/2" S (HLT)	○	X	—	—	—	ON	—	—

L: Lengthwise S: Sideways X: No ○: Yes ON: Paper present

○<sub>1</sub>, ●<sub>1</sub>: If the original is 11" x 15" L, it will always be detected as 11" x 17" L (DLT).  
 ○<sub>2</sub>, ●<sub>2</sub>: In North American models, if the original is 8" x 13" L (F size), it will always be detected as 8 1/2" x 14" L (LG).  
 ○<sub>3</sub>, ●<sub>3</sub>: If the original is 10" x 8" L, it will always be detected as 8 1/2" x 11" L (LT).  
 ○<sub>4</sub>, ●<sub>4</sub>: In Europe/Asia models, if the original is 8" x 13" L (F size), it will always be detected as 8 1/2" x 13" L (F4 size).

NA: North America, EU: Europe

**- Original Width Sensor -**

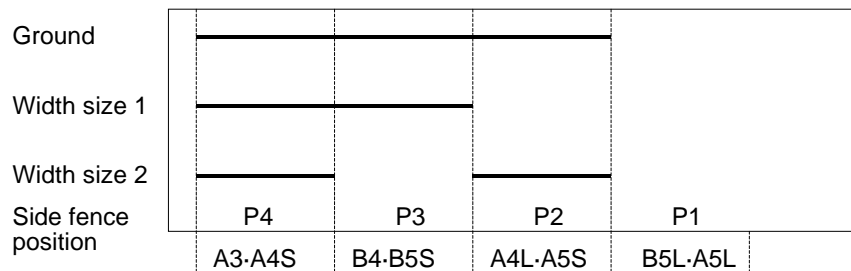

C600D512.WMF

Options



## 2.2 PICK-UP AND SEPARATION

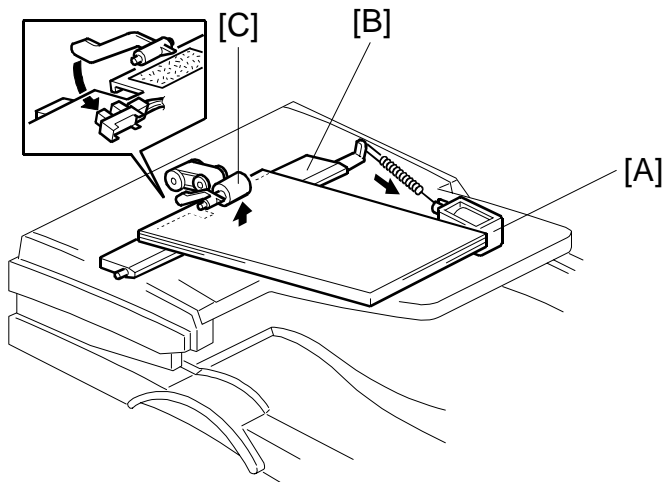

C600D105.WMF

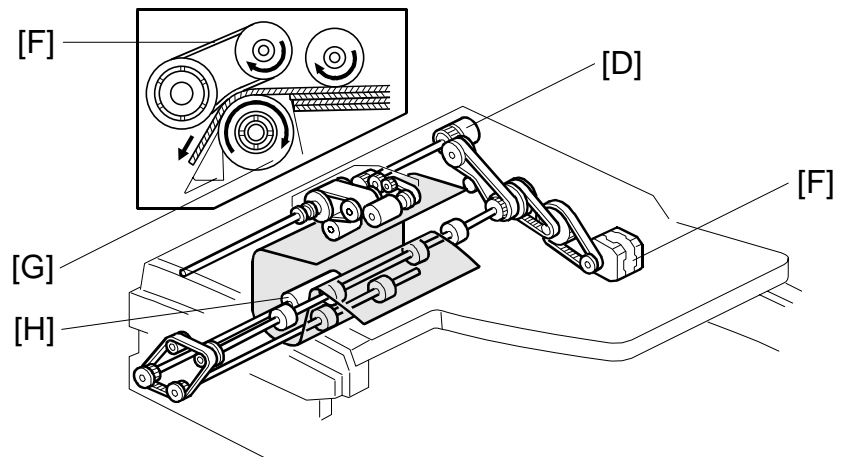

C600D106.WMF

When the print key is pressed, the DF pick-up solenoid [A] turns on and the entrance guide [B] lifts up the originals to the pick-up roller [C]. At the same time, the DF feed clutch [D] turns on.

200 ms after this, the DF transport motor [E] turns on. The original is fed to the paper feed belt [F] from the top page. The pages are separated by the separation roller [G] and the top sheet of the original is fed to the 1st transport roller [H]. The original separation system uses an FRR system.

## 2.3 ORIGINAL TRANSPORT AND EXIT MECHANISM

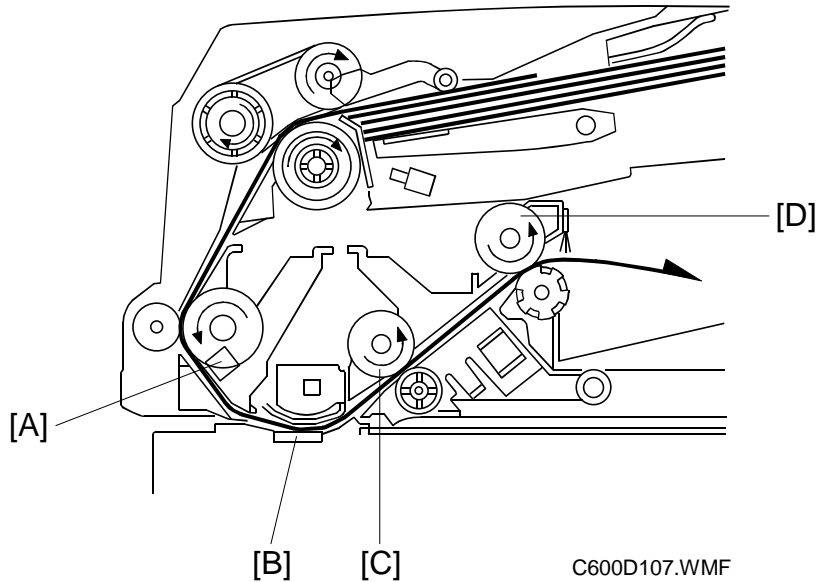

When the leading edge of the original reaches the registration sensor [A], the DF transport motors turn off. After a short time the DF transport motors turn on again. The original is fed past the DF exposure glass [B], where it is scanned. The original is fed through to the 2nd transport roller [C] and fed out by the exit roller [D].

The DF transport motor speed, while feeding the original to the registration sensor, is constant. However, when the motor turns on again to feed the original to the exposure glass, the speed depends on the selected reproduction ratio. At 100%, it is 90 mm/s.

## 2.4 OVERALL ELECTRICAL CIRCUIT

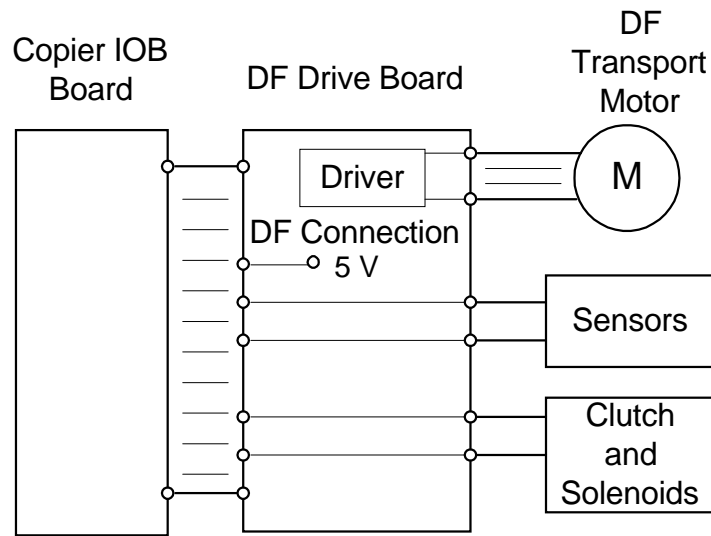

C600D509.WMF

The copier directly controls the DF pick-up solenoid, stamp solenoid, and DF feed clutch through the DF drive board. The sensor signals are directly sent to the copier through the DF drive board. The DF drive board has a driver for the DF transport motor and the drive signals are sent from the copier.

When the DF connector is connected to the copier IOB board, the DF connection signal to the copier goes to 5 V. Then the copier detects that the DF is connected.

## 3. REPLACEMENT AND ADJUSTMENT

### 3.1 FEED UNIT REMOVAL

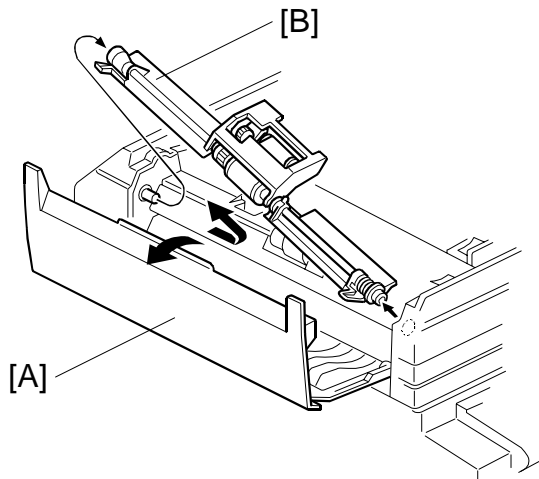

C600R102.WMF

1. Open the DF feed cover [A].
2. Slide the feed unit [B] in the direction of the arrow, then remove it.

### 3.2 SEPARATION ROLLER REPLACEMENT

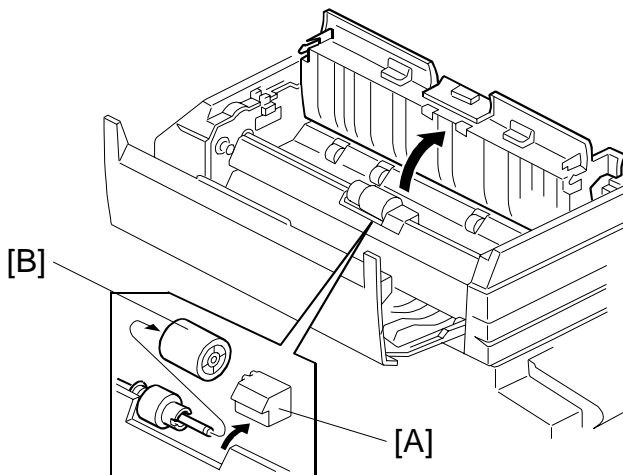

C600R105.WMF

1. Remove the feed unit.
2. Remove the separation roller cover [A].
3. Replace the separation roller [B].

### 3.3 PICK-UP ROLLER REPLACEMENT

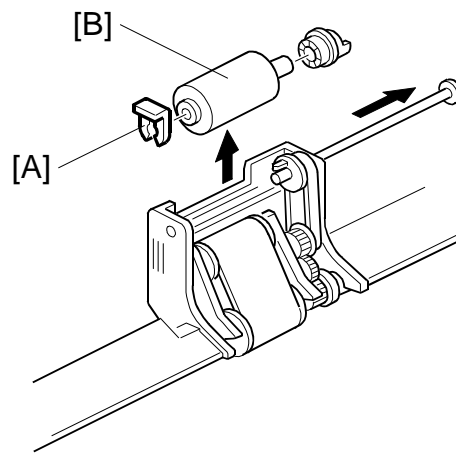

C600R103.WMF

1. Remove the feed unit.
2. Remove the snap ring [A].
3. Replace the pick-up roller [B].

### 3.4 FEED BELT REPLACEMENT

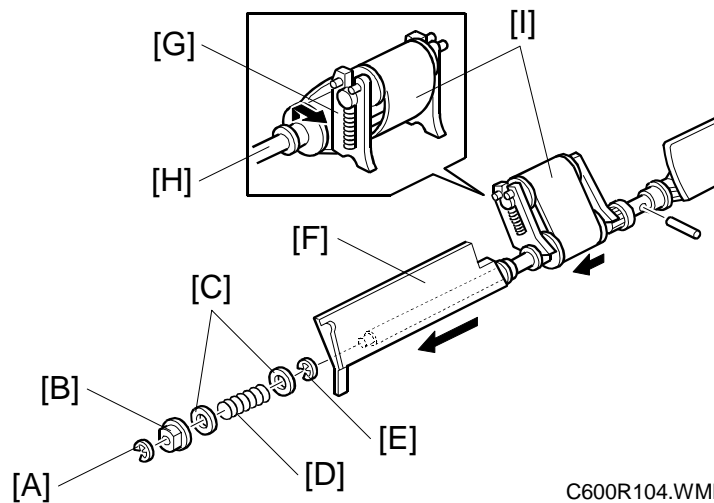

C600R104.WMF

1. Remove the feed unit.
2. Remove the E-ring [A], bearing [B], washers [C], and spring [D].
3. Remove the E-ring [E], and remove the original guide [F].
4. Release the idle roller holder [G] from the drive roller shaft [H], then release the idle roller.
5. Replace the feed belt [I].

### 3.5 ORIGINAL SET SENSOR REPLACEMENT

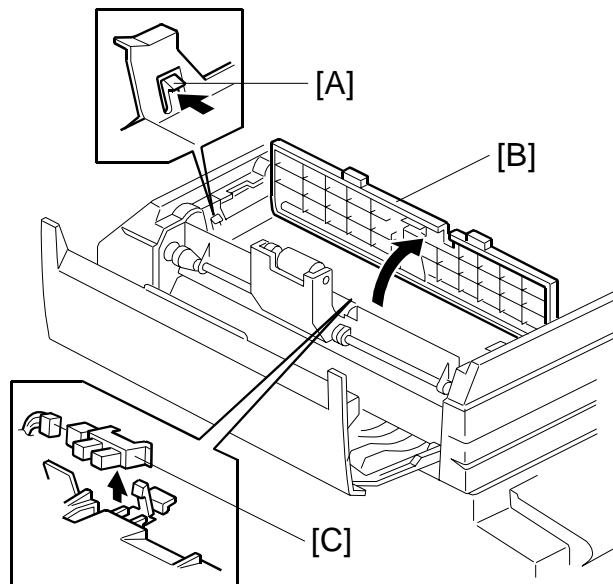

C600R106.WMF

1. Remove the DF feed cover.
2. While releasing the front and rear stoppers [A], open the transport guide [B].
3. Replace the original set sensor [C].

### 3.6 ORIGINAL WIDTH/LENGTH/TRAILING EDGE SENSOR REPLACEMENT

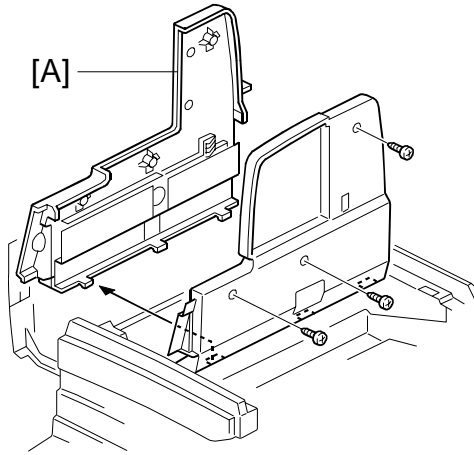

C600R107.WMF

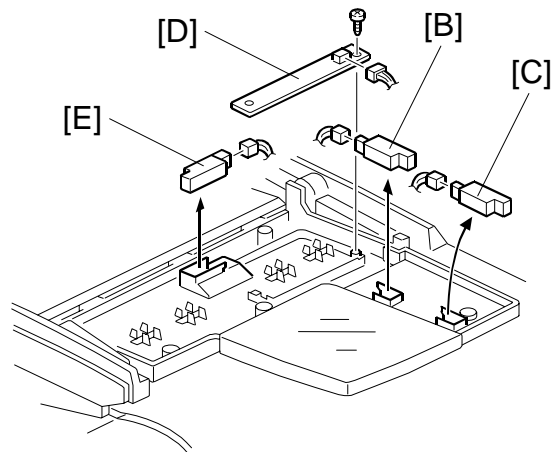

C600R108.WMF

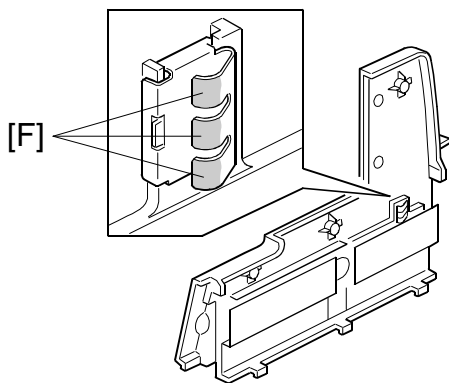

C600R113.WMF

1. Open the original table.
2. Remove the original guide [A] (3 screws).
3. Replace the following sensors:
  - Original length sensor 1 [B]
  - Original length sensor 2 [C]
  - Original width sensor (1 screw) [D]
  - Original trailing edge sensor [E]

**NOTE:** To prevent incorrect size detection, clean the electrode [F] of the original width sensor using alcohol or a dry cloth. Then apply conductive grease KS-660 (G0049668).

### 3.7 ORIGINAL EXIT TRAY/FRONT COVER/REAR COVER REMOVAL

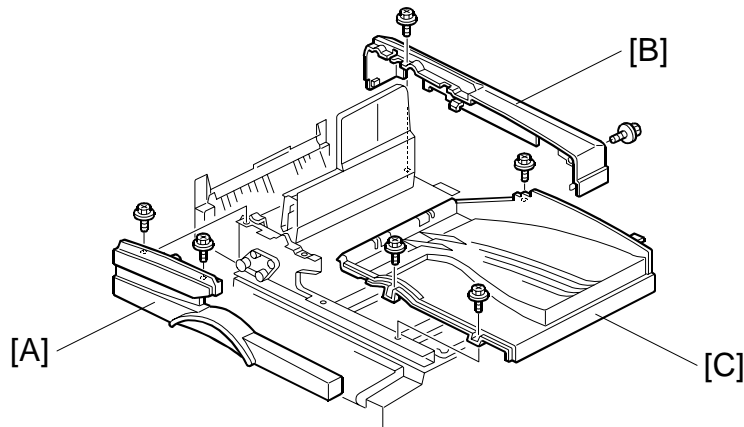

C600R101.WMF

1. Open the DF feed cover.
2. Open the original table.
3. Remove the front cover [A] (2 screws).
4. Remove the rear cover [B] (2 screws).
5. Remove the original exit tray [C] (3 screws).

### 3.8 FEED COVER OPEN SENSOR/DF OPEN SENSOR REPLACEMENT

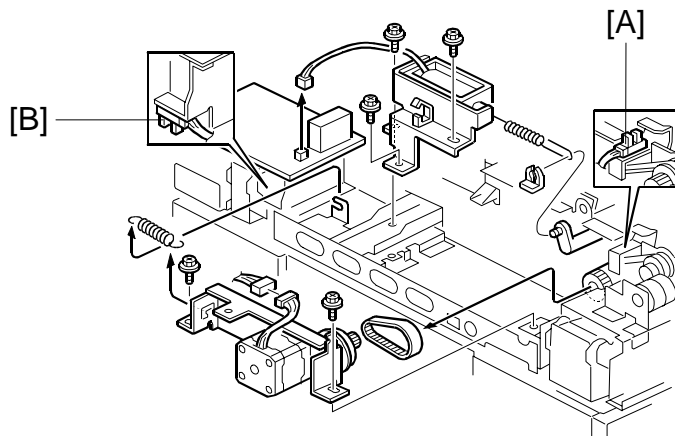

C600R159.WMF

1. Remove the rear cover (2 screws).
2. Replace the following sensors:
  - Feed cover open sensor [A].
  - DF open sensor [B]



### 3.9 FEED CLUTCH/PICK-UP SOL/TRANSPORT MOTOR REPLACEMENT

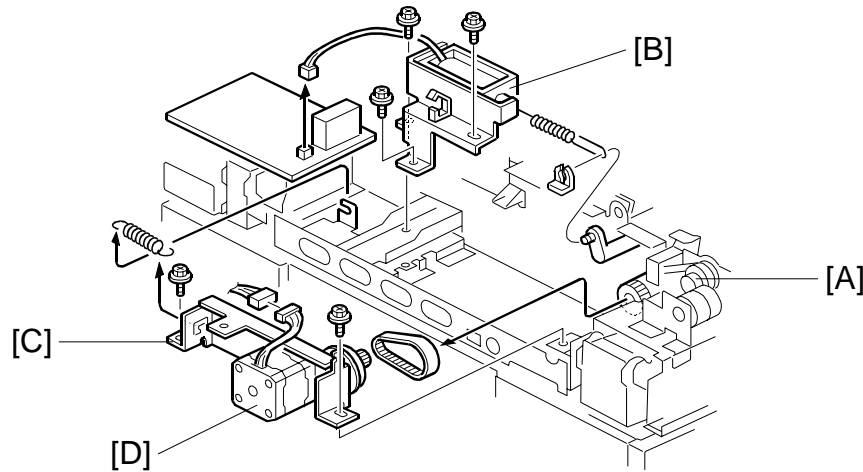

C600R109.WMF

1. Remove the rear cover (2 screws).

#### - Feed Clutch -

2. Replace the feed clutch [A] (1 E-ring and 1 connector).

#### - Pick-up Solenoid -

3. Replace the pick-up solenoid [B] (3 screws and 1 connector).

#### - Transport Motor -

4. Remove the transport motor bracket [C] (2 screws).

5. Remove the transport motor [D] (2 screws, 1 connector).

### 3.10 DF FEED COVER REMOVAL

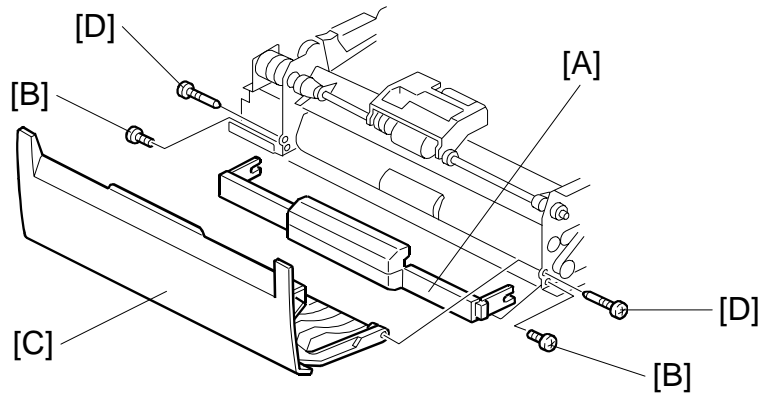

C600R110.WMF

1. Remove the front cover (2 screws) and the rear cover (2 screws).
2. Remove the turn guide [A] (2 screws [B]).
3. Remove the DF feed cover [C] (2 screws [D]).

### 3.11 REGISTRATION SENSOR REPLACEMENT

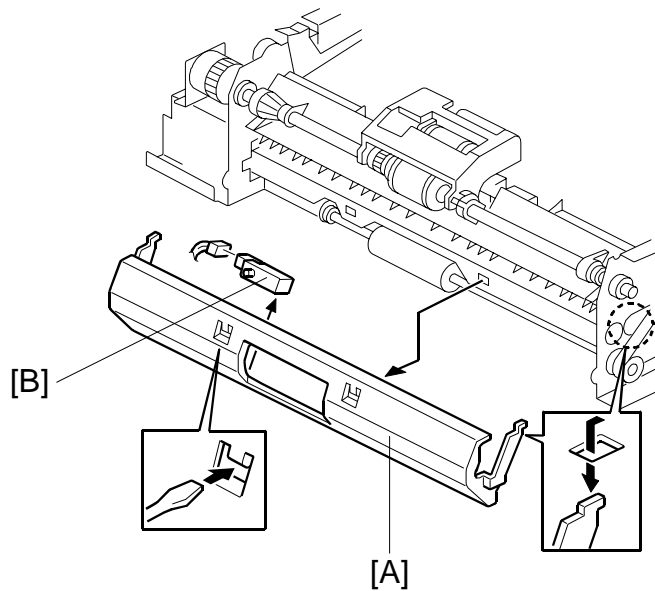

C600R111.WMF

1. Remove the front cover (2 screws) and the rear cover (2 screws).
2. Remove the transport guide [A].
3. Replace the registration sensor [B].

Options